

CMC House Plot

R. David Wilson Jr.
Light Designer

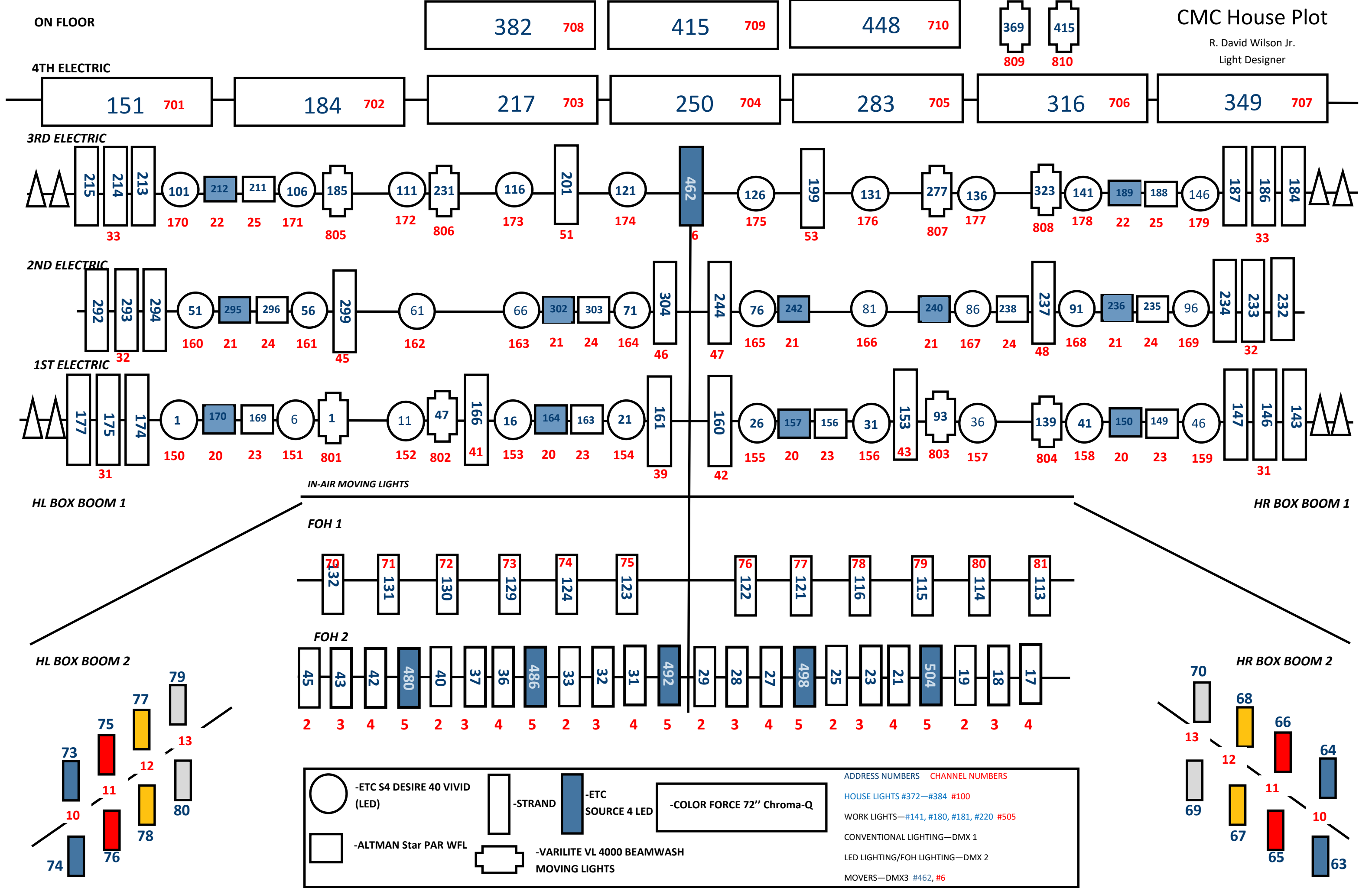

	-ETC S4 DESIRE 40 VIVID (LED)		-STRAND		-ETC SOURCE 4 LED		-COLOR FORCE 72" Chroma-Q
	-ALTMAN Star PAR WFL		-VARILITE VL 4000 BEAMWASH MOVING LIGHTS	ADDRESS NUMBERS CHANNEL NUMBERS HOUSE LIGHTS #372—#384 #100 WORK LIGHTS—#141, #180, #181, #220 #505 CONVENTIONAL LIGHTING—DMX 1 LED LIGHTING/FOH LIGHTING—DMX 2 MOVERS—DMX3 #462, #6			

PARKED LIGHTING FOR LEDS

FIRST ELECTRIC LED PARKED—ADDRESS 144, 176—UNIVERSE 1

SECOND ELECTRIC LED PARKED—ADDRESS 239, 301—UNIVERSE 1

THIRD ELECTRIC LED PARKED—ADDRESS 185, 216—UNIVERSE 1

FOURTH ELECTRIC LED PARKED—ADDRESS 100, 263, 264, 265, 266, 267, 268—UNIVERSE 1

FRONT OF HOUSE LED PARKED—ADDRESS 41, 35, 30, 26, 20—UNIVERSE 1

THIRD ELECTRIC ETC SPECIAL LED PARKED—ADDRESS 200—UNIVERSE 1

BLUE LIGHTS SIDE OF STAGE

ADDRESSES 141, 180, 181, 220—UNIVERSE 1